

## Personal Safety Advice

If you feel at risk from another person, return to your vehicle by a left-hand door and lock all doors.

Leave your vehicle again as soon as you feel this danger has passed. Remember that you are normally much safer waiting in a safe area away from your vehicle.

## Advice for Disabled Drivers



If you have a disability that prevents you from following the advice in this leaflet you should:

- Stay in your vehicle
- Switch on your hazard warning lights
- Display a 'Help' pennant or, if you have a car or mobile telephone, contact the emergency services and advise them of your location

## Journey Planning Information

Before you leave on your journey remember to:

- Check your route
- Check you have enough fuel
- Allow 15 minutes break for every two hours driving

## Surviving the Hard Shoulder

For current travel information visit

England: [www.highways.gov.uk/trafficinfo](http://www.highways.gov.uk/trafficinfo)

Wales: [www.traffic-wales.com](http://www.traffic-wales.com)

Scotland: [www.trafficscotland.org](http://www.trafficscotland.org)

General: [www.transportdirect.info](http://www.transportdirect.info)



### Working in Partnership



Safe Use of Roadside Verges  
In Vehicular Emergencies

## Surviving the Hard Shoulder



Birmingham B060366. © Crown copyright 2006.  
Printed on paper from a sustainable source.

## Surviving the Hard Shoulder

**Remember – the hard shoulder is a dangerous place.**

If your vehicle develops a problem, pull into a service area or leave at the next exit if you can. **Only stop on the hard shoulder in an emergency** and follow the advice in this leaflet to reduce the risk of death and injury to you, your passengers and other road users.

Motorists have a role in reducing death and injury to themselves and to those attending any kind of emergency on the motorway or on high speed dual carriageways.

### Hard Shoulder Dos and Don'ts

**Do** stop on the hard shoulder:

- ✓ **Only in an emergency, when you have no other choice**

**Do not** stop on the hard shoulder to:

- ✗ Use a mobile telephone
- ✗ Go to the toilet
- ✗ Attend to children
- ✗ Check a route or map
- ✗ Exercise a pet
- ✗ Stretch your legs
- ✗ Have a cup of tea or eat a sandwich
- ✗ Have a sleep

## What to do when you have to stop on the hard shoulder

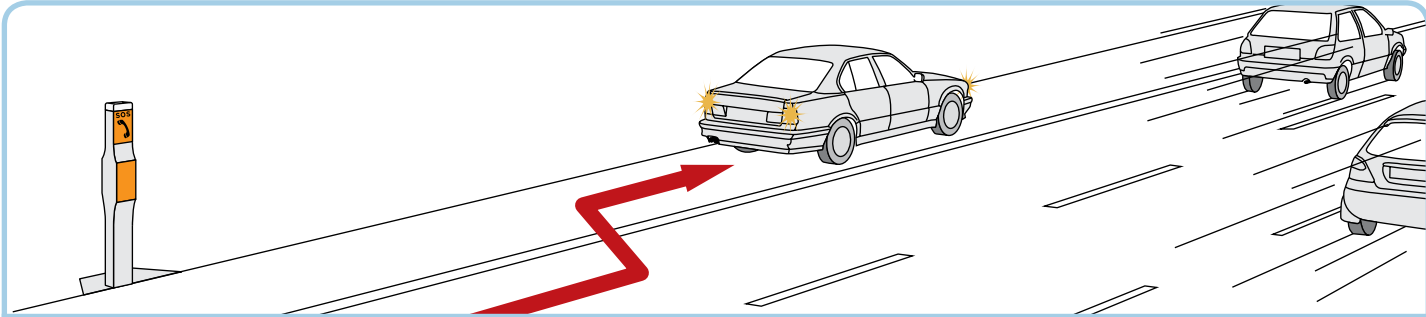

Pull onto the hard shoulder and stop as far to the left as possible. Put on your hazard warning lights and, if it is dark or visibility is poor, your sidelights.

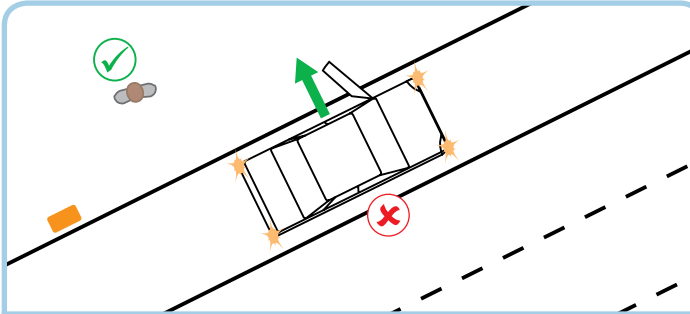

Make sure that you and all occupants leave the vehicle by the left hand doors. Leave any animals in the vehicle.

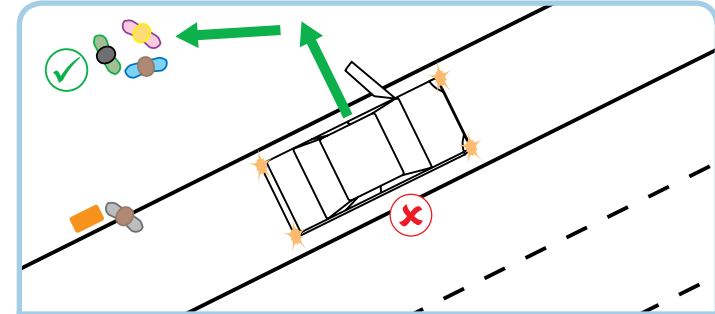

Do not attempt even simple repairs. Move to a safe area away from the carriageway. Keep children under control.

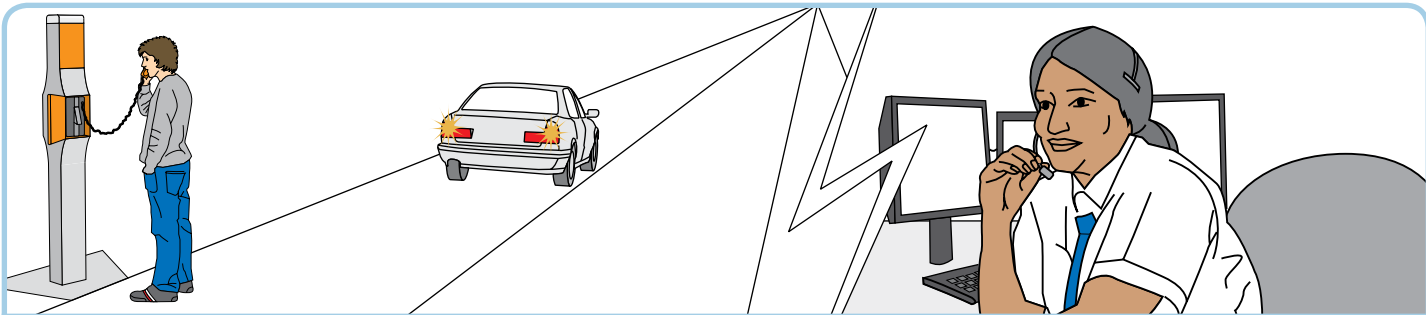

Walk to the nearest emergency telephone to call for help if you can. Be aware of the traffic at all times. Use the emergency telephone in preference to a mobile phone as this will allow the operator to pinpoint your position, and get help to you quickly.

- The risk of a fatal or serious accident to an occupant of a parked vehicle is about 3 times that of driving along the motorway
- 32% of accidents on the hard shoulder are fatal or serious, compared with 13% of all motorway accidents
- On average around 50 people every year are killed or seriously injured in hard shoulder accidents